

# FLUSHLINE SINK & DRAINER

PRODUCT CODE: SK36

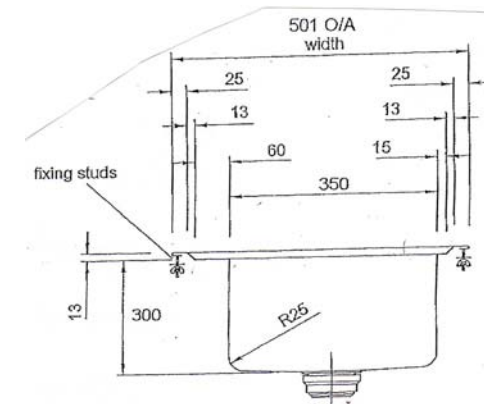
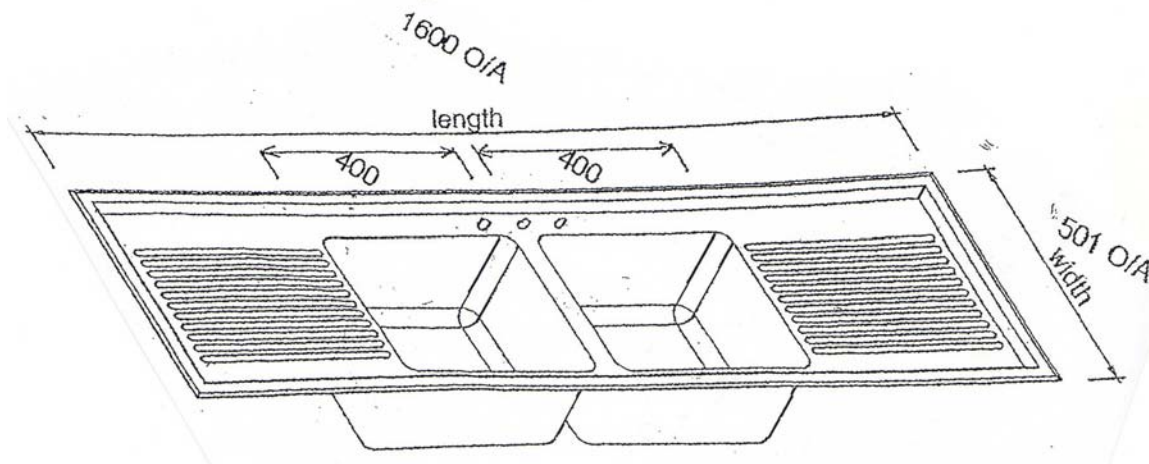

## Specification

Grade 316 stainless steel  
Thickness 1.2mm  
Dimensions over all 1600mm x 501mm

## Bowls :

400mm long  
350mm Wide  
300mm deep



23-27 Clapham Road  
Regents Park NSW 2143

Ph: 02 9644 2811  
Fx: 02 9645 1114

DRAWING NO: SC145  
05/10

Southern Cross Stainless Steel  
**Southern Cross Stainless Steel**